

---

**INSTALLATION  
AND  
OPERATIONS  
MANUAL  
IGSI-1500SJ to IGSI-6000SJ**

---

## REVISION TABLE

Document Revision	Author	Date	Change Description
0	KL Tan	01/04/2012	First release



**SAVE THESE INSTRUCTIONS !**



**IMPORTANT SAFETY INSTRUCTIONS**

**NOTE:** Reproduction and disclosure of the contents of this manual are strictly forbidden without prior authorization of the manufacturer

## GENERAL PRECAUTIONS

**For your own safety and that of the unit, you must read and understand the instructions contained in this document before starting to work.**

**Keep these instructions in a place accessible to all the personnel who work with the unit so that these may be consulted.**

**Only professional technician may install and operate our units.**

### WARNING:







To avoid risk of electric shock from energy stored in capacitor, please wait for at least 5 minutes to access the conductor part of input or output terminals of the inverter after it is disconnected from the output of PV panel and AC grid.

There is a fuse in our units. For continued protection against risk of fire, replace only with same type and ratings of fuse. The replacement should be done by qualified service personnel.

- The installation of inverter must be performed in full compliance with the National Wiring Rules of Standard AS/NZS 3000 and other relative local standards and regulations.
- There are no spare parts in package box. To avoid risk of electric shock, Do not remove machine cover. No user serviceable parts inside. Refer servicing to qualified service personnel. Please contact your reseller if you need to know the nearest authorized repair center or qualified service personnel.
- As a qualified service personnel, you should know both ac and dc voltage sources are terminated inside this units. Each circuit must be individually disconnected before servicing.
- Read and understand all the instructions contained in this manual and become familiar with the safety symbols in the relevant paragraphs before you install and commission the equipment.
- The connection to the AC grid must be done only after receiving approval from the administering authority as required by national and state interconnection regulations, and can be done only by qualified personnel.
- Keep the whole surface of the photovoltaic panel covered with material opaque to solar radiation before connecting panel to equipment; this will ensure that no dangerous high voltage is present at the connection cables.
- This unit is designed to feed power to the public power grid (utility) only. Do not connect this unit to an AC source or generator. Connecting Inverter to external devices could result in serious damage to your equipment.
- Although designed to meet all safety requirements, some parts and surfaces of Inverter are still hot during operation. To reduce the risk of injury, do not touch the heat sink at the back of the solar inverter or nearby surfaces while Inverter is operating. Keep it away from any flammable objects.
- This version of IGSI “SJ” series inverters shall be used with panels connected in a “floating” way, i.e. with positive and negative terminal not connected to the ground.

The equipment is provided with several labels, some of them with a yellow background, and these are related to safety issues.

Make sure to read the labels and fully understand them before installing the equipment.  
The symbols are:

	Equipment grounding conductor (Main grounding protective earth, PE)
	Alternate Current (AC) value
	Direct Current (DC) value
	Phase
	Grounding (Earth)

## CONTENT

<b>1. OVERVIEW</b> .....	6
<b>2. INSTALLATION</b> .....	8
2.1 Package inspection .....	8
2.2 Selecting the place of installation .....	8
2.3 Fixed on the wall.....	9
2.4 System diagram and connection label .....	11
2.5 Connecting to the AC grid (utility).....	12
2.6 Connecting to PV Panel (DC input) .....	12
<b>3. CONTROL PANEL FUNCTIONS</b> .....	13
3.1 Operate the Function Key .....	14
3.2 General LCD Display Information .....	16
<b>4. INVERTER START-UP AND OPERATION</b> .....	17
<b>5. COMMUNICATIONS</b> .....	18
5.1 Data communications with RS232 .....	18
5.2 Data communications with RS485 (optional).....	19
5.2.1 RS485 Serial Port .....	19
5.2.2 RJ45 Connectors.....	19
5.2.3 RS485 Daisy Chain .....	20
5.3 Monitor Inverter .....	21
<b>6. MAINTENANCE</b> .....	21
<b>7. TROUBLE SHOOTING</b> .....	21
<b>8. SPECIFICATIONS</b> .....	23

# 1. OVERVIEW

## 1.1 Product Overview

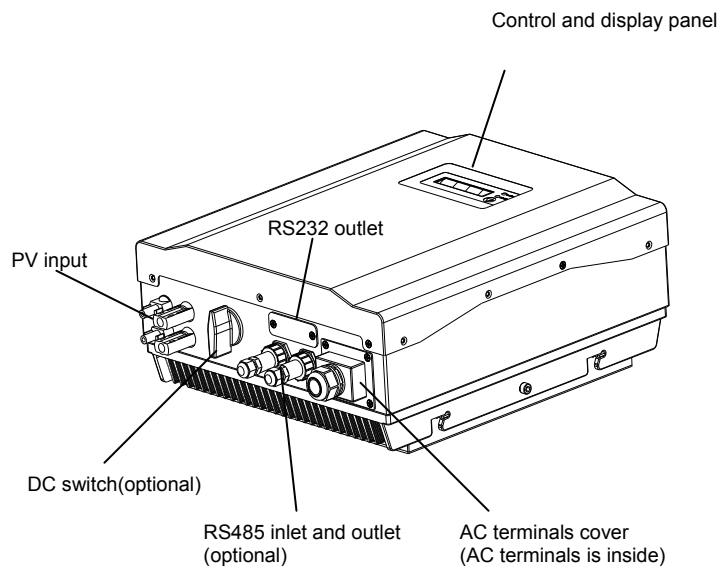

Front View

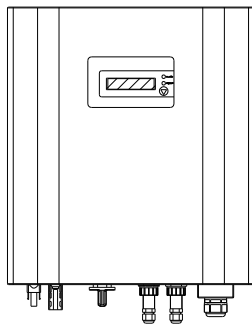

Bottom View

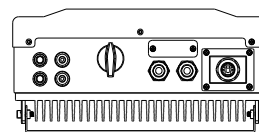

Fig.1 Overview of inverter

## Opening the package

After opening the package, please check the contents of the box. It should contain the following accessories:

Item	Name	Quantity
1.	Solar inverter	1pc
2.	Mounting frame	1pc
3.	Mounting screws and blocks	6pcs/9pcs
4.	Safety-lock screws	2pcs/4pcs
5.	Socket head wrench	1pc
6.	DC socket assembly	1set
7.	RS-485 sockets, one with 120 ohm terminal resistor	Optional
8.	Special RS-232 cable	1pc
9.	Instruction manual	1pc
10.	Monitor software(CD)	1pc
11.	Warranty sheet	1pc

**IGSI “SJ” series products include IGSI-1500SJ, IGSI-2000SJ, IGSI-3000SJ, IGSI-5000SJ, IGSI-6000SJ.**

**For requirements with an integrated DC switch, please add a –S suffix.**

## 2. INSTALLATION



**WARNING:** The electrical installation of IGSI “SJ” series inverter must be performed in compliance with applicable local and national standards and laws.



**WARNING:** The connection of IGSI “SJ” series inverter to the AC grid must be performed only after receiving authorization from the utility that operates the grid.

### 2.1 Package Inspection

The customer is encouraged to perform the following checks:

- Inspect the package box for apparent damage, such as holes, cracking or any sign of possible damage to its contents.
- Describe any damage or shortage on the receiving documents and have the carrier sign his/her full name.
- Open the package box and inspect the contents for internal damage. While unpacking, be careful not to discard any equipment, parts or manuals. If any damage is detected, call the delivering carrier to determine the appropriate action. Save all shipping material for the event the carrier sends an inspector to verify damage!
- If the inspection reveals damage to the inverter, please call your local supplier or the authorized distributor. They will determine if the equipment should be returned for repair. They will also provide instructions on how to get the equipment repaired;
- It is the customer’s responsibility to file a claim with the carrier. Failure to file a claim with the carrier may void all warranty service rights for any damage;
- Carefully store the original packaging of IGSI “SJ” series inverter since it shall be used in case it is necessary to ship it for repair.

### 2.2 Selecting the place of installation

Place of installation should be selected based on the following considerations:

- IGSI “SJ” series inverters shall be set at a suitable height from the ground to enable easy readout view of the display and the LEDs.
- Select a well ventilated place sheltered from direct sun radiation. Choose a place that allows fluent air flow around the unit.
- Allow sufficient room around the unit to enable easy installation and removal of the object from its mounting surface.



The following figure shows the recommended minimum clearances around the inverter:

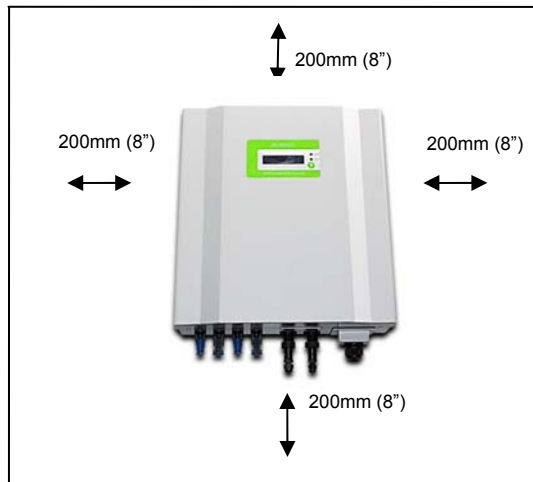

Fig.2 Installing minimum clearances around inverter

### 2.3 Fixed on the wall

Step1: Drill 6 or 9 holes as illustrated in the Fig.3

Step2: Fix the mounting frame as illustrated in the Fig.4 by the screws, then hang the inverter on the mounting frame.

Step3: Fix safety-lock screws at left side and right side as illustrated in Fig.5 with the attached socket head wrench.

Step4: Check the installation conditions.

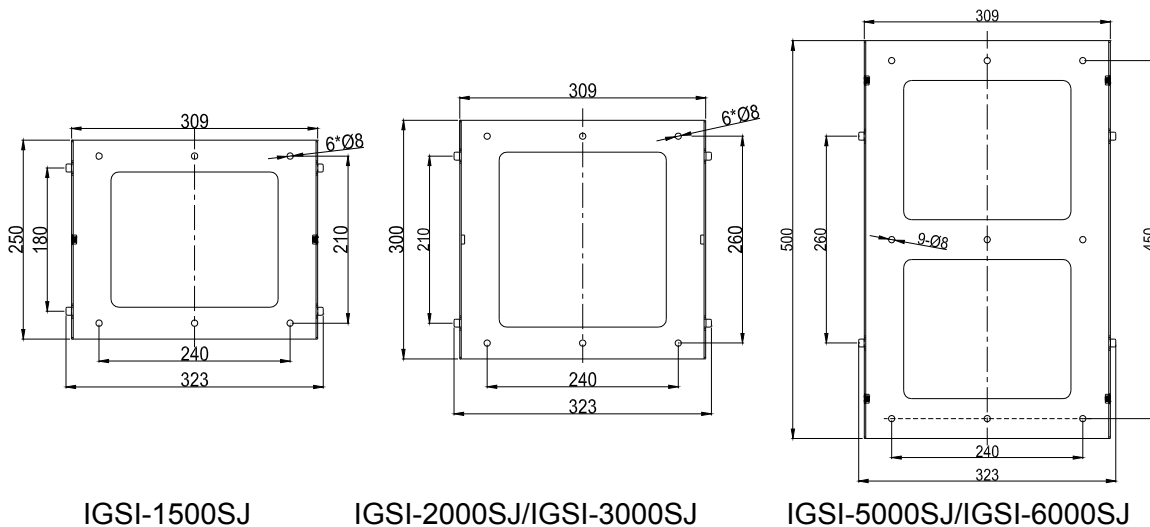

Fig.3 The size of mounting frame

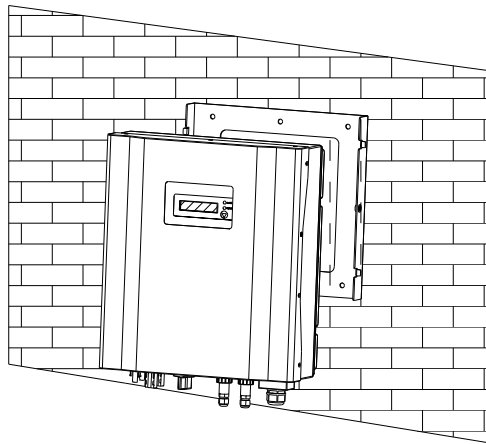

Fig.4 Hang inverter to mounting frame

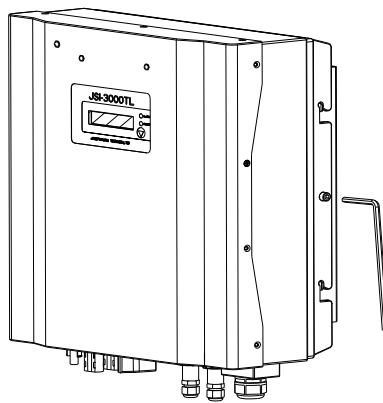

Fig.5 Fix safety-lock screws

The customer is encouraged to perform the following checks:

- Do not install the solar inverter on a gradient surface.
- Check the upper straps of solar inverter and ensure it to fit on to the bracket.
- Ensure safety-lock screws (M5 socket head cap screws) to insert into the mounting frame through inverter's heat-sink.
- Check the secure mounting of the solar inverter by trying to raise it from the bottom. The solar inverter should remain firmly attached.
- Choose a strong mounting wall to prevent vibrations while inverter is operating.

## 2.4 System Diagram and Connection Label

The IGSI “SJ” series are single phase solar inverters. They are designed to convert the direct current generated by PV panels into single-phase 230Vac 50Hz alternating current for delivery into the AC grid.

The IGSI “SJ” series can be used in an on-grid PV system to produce electricity.

The installation of the IGSI “SJ” series and their connection to the AC grid shall be done in accordance with local regulations and may require the installation of adequate electricity consumption measuring devices.

The IGSI “SJ” series only operate when it is connected to the AC grid and cannot operate as a stand-alone unit.

The simplified connection diagram of the inverter is as follows.

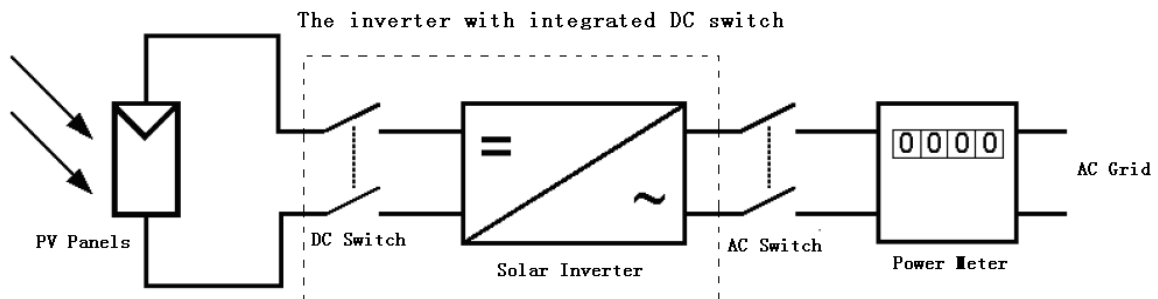

Fig.6 The PV system diagram

- A. PV Panels: Provide DC power to inverter.
- B. Solar inverter: Converts DC (Direct Current) power from PV panel(s) to AC (Alternating Current) power. As the Inverter is grid-connected, it controls the current amplitude according to the PV Panel power supply. The PV inverter always tries to convert the maximum power from your PV panel(s).
- C. DC Switch and AC Switch: “DC switch” is located between PV Panels and solar inverter while “AC Switch” located is between AC Grid (Utility) and solar Inverter. They are simplified in this diagram. Usually, they may consist of electrical breaker, fuse and/or connecting terminals. To comply with local safety standards and codes, the connection system should be designed and implemented by a qualified technician. The solar inverter also has an option of an integrated DC switch demonstrated in dashed border in Fig.6. –S suffix indicates the inverter is integrated a DC switch in PV input side.
- D. AC Grid (Utility): Referred to as “grid” in this manual, is the way your electric power company provides power to your place. Please note that Inverter can only connect to low-voltage systems (namely, 220/230Vac, 50Hz).

**Note:** There is an option of an integrated switch box that includes DC switch, AC switch, DC fuse, AC fuse, DC SPD and AC SPD devices as an option. Such a product is also readily available from your local market.



Fig. 7 Connections available on inverter bottom and relevant marking

- E. PV INPUT: Connected to PV Panels by MC4 terminals.
- F. RS232: Connected to monitoring computer by special RS232 cable.
- G. RS485: daisy-chain communication for one or more inverters.
- H. AC TERMINAL (three blocks in right hand): Connected to AC Grid.

## 2.5 Connecting to the AC Grid (Utility)

- A. Measure AC grid (utility) voltage and frequency. It should be 230VAC (or 220VAC), 50Hz and single phase.
- B. Open AC Switch between solar inverter and AC Grid (Utility).
- C. Open AC terminals cover and connect AC wires on AC terminals as follows:

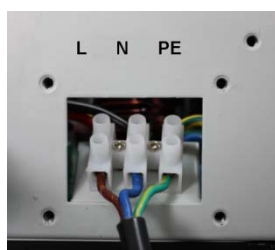

Fig. 8 AC terminals under AC terminals cover

Recommended AC wires			
Model	Diameter(mm)	Cross Area(mm <sup>2</sup> )	AWG no.
IGSI-1500SJ	1.83	2.63	13
IGSI-2000SJ IGSI-3000SJ	2.05	3.31	12
IGSI-5000SJ IGSI-6000SJ	2.59	5.27	10

## 2.6 Connecting to PV Panel (DC input)

- A. **Under any condition!** Make sure the maximum open circuit voltage (Voc) of each PV string is less than 550VDC for IGSI-5000SJ and IGSI-6000SJ; and less than 500VDC for IGSI-2000SJ and IGSI-3000SJ; and less than 450VDC for IGSI-1500SJ. The length of input cable must be less than 30m. Generally, during the lowest ambient temperature of your installing field, the Voc of PV string is the highest.

- B. Use MC4 (Multi-contact) connectors for PV array terminals.
- C. Open DC Switch and Connect the positive and negative terminals from the PV panel to DC switch, then to positive (+) terminals and negative (-) terminals on the solar inverter. Each DC terminal on inverter can withstand 20A<sub>dc</sub>.
- D. When connecting PV panels to DC Switch, then, DC Switch to the terminals of inverter, please make sure the polarity is correct.  
**Incorrect polarity connection could permanently damage the unit.** Please confirm short-circuit current of the PV string. The total short-circuit current of the PV string should be less than the inverter's maximum DC input current.
- E. High voltages exist when the PV panel is exposed to the sun. To reduce risk of electric shock, avoid touching live components and treat connection terminals carefully.

**Note:** Ensure that photovoltaic field voltage polarity matches the “+” and “-” symbols. Before connecting IGSI “SJ” series inverters with the photovoltaic field, it is recommended to check, using a proper gauge, that the polarity value and the voltage allowed value between positive and negative contacts are correct.

### 3. CONTROL PANEL FUNCTIONS

There is an LCD screen, two LEDs and one function key on the front of the solar inverter. The LCD and LED provide you with details of the status of your Inverter. You also can use this function key as a simple control.



Fig. 9 Control panel

- A. LCD Screen: Display the operating data and situations, warning/error codes and information.
- B. The model of inverter (for example,IGSI-3000SJ)
- C. ALARM LED: Indicates the fault of inverter.
- D. POWER LED: Indicates the inverter is running normally.
- E. Function Key: Used to set different parameter and display language for the inverter.
- F. Description of inverter.

**Note:** To save power, the LCD display's backlight automatically turns off after 10 seconds.

### 3.1 Operate the Function Key

To view the operating data of the inverter, you can press the function Key. The data will also display the parameters periodically. To set different display contrast and display language for the inverter, please refer to the following chart.

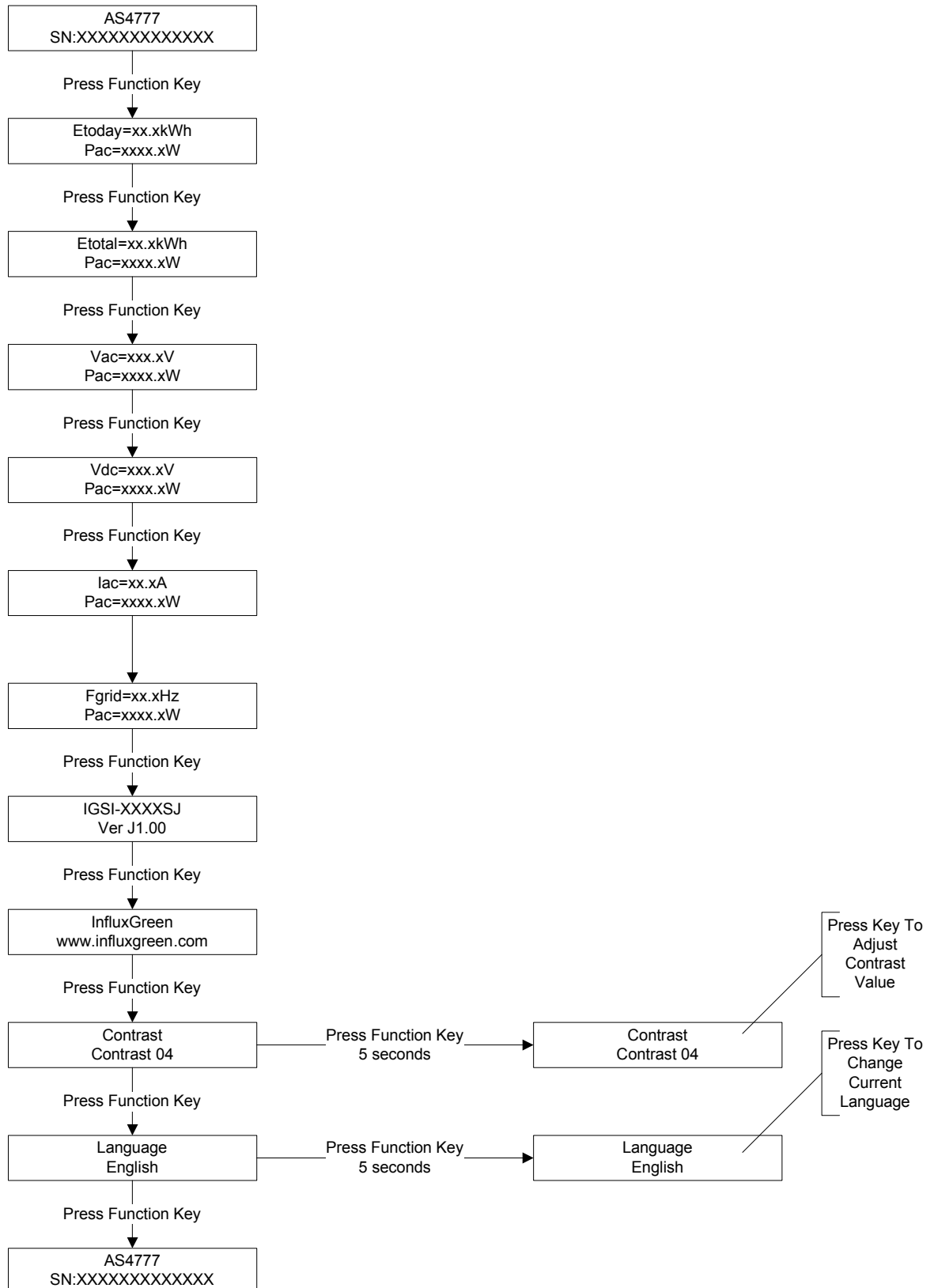

To lockup or unlock display message as follows:

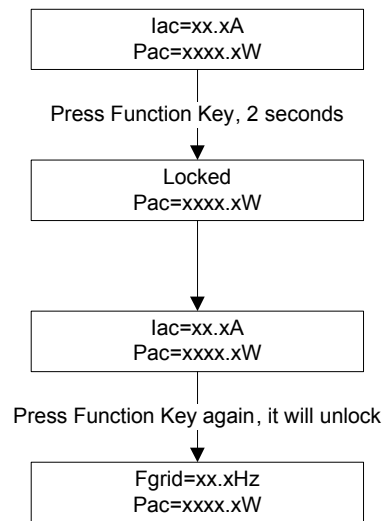

### 3.2 General LCD Display Information

State Message In LCD		
STATE	DISPLAY CONTENT	COMMENTS
Wait State	Standby	PV input voltage low
	Waiting	Initial waiting
	Connect in xxS	System checking
	Reconnect in xxS	System checking
Inverter	Connect OK	Connect to Grid
Fault State	Exx	System error code
	Wxx	System warning code
Auto Test State	Auto Testing	Protection auto test
Program State	Programming	Update Software

Main Operating Messages In LCD		
STATE	DISPLAY CONTENT	COMMENTS
Normal Operation	InfluxGreen Energy P/L	Company name
	www.influxgreen.com	Website
	JSI-xxxTL	The inverter model
	Ver Jx.x	The FW version
	SN: xxxxxxx	The Serial Number
	Etoday = xx.xkWh	The energy today
	Ettotal = xxxkWH	The total energy in lifetime
	Pac = xxxx.xW	The output power of inverter
	Iac = xx.xA	The output current of inverter
	Vac = xxx.xV	The grid voltage
	Fgrid = xx.xHz	The grid frequency
	Vdc=xxx.xV	The PV input voltage
	AS4777	Comply with main standard
	English	Current selected language
	Contrast x	LCD Contrast
	Fgrid = xx Hz	The grid frequency
<p><b>Note: Etoday will display the output energy in last day before the inverter continuously work until 30 minutes in the early morning.</b></p>		



## 4. INVERTER START-UP AND OPERATION



**WARNING:** Do not place any items on IGSI inverter during operation.  
When the inverter is operating, do not touch the heat sink since some parts may become very hot.

**Step 1:** Ensure that the AC cable and DC cable is connected correctly, unused DC plugs and AC terminal cover are sealed.

**Step 2:** Connect the DC and AC switches. The inverter starts up automatically when DC-power from the PV strings is sufficient.  
Once the solar inverter starts, it enters one of the following 3 states in turn:

Standby: The PV string can only provide just enough voltage to minimum requirements of the internal controller unit.

Waiting: When the PV string DC voltage is greater than 100V, the inverter enters a “waiting” state and attempts to connect to the grid.

Normal: When PV string DC voltage is greater than 150V, the inverter operates in the normal state.

The inverter will keep MPPT function and deliver power to AC Grid when it is in normal operation. At low input DC-power, the inverter may stop operation. However, it will automatically restart again when DC-power from the PV string is within the operating range again.

## **Error or Warning status**

The inverter is designed to be as user-friendly as possible. Therefore, the error or warning status of the inverter can be easily understood by reading the information shown on the front panel display. All possible messages are shown in the following table.

<b>DISPLAY</b>		<b>COMMENTS</b>
<b>System fault</b>		
Auto Test Failed		Auto Test does not pass
W01	No grid	No Utility, No Grid Connect
W02	Vin overvoltage	PV panel Voltage is too high
E01 Isolation error		Insulation Problem of PV panel
E02	Ileak error	GFCI Fault, leakage current is
E03	Grid fault	Grid voltage/frequency is out of
<b>Inverter fault</b>		
E04	Coherence error	Consistent Fault
E05	Over temperature	Internal temperature abnormal
E06	Relay failure	Output relay Fault
E07	DCinj failure	Output Current DC Offset too
E08	EEPROM failure	EEPROM Fault
E09	Com. failure	Communication Fault
E10	DC bus OV.	DC Bus over-voltage
E11	DC bus UV.	DC Bus under-voltage
E12	Vref error	2.5V Reference Voltage Fault
E13	DC sensor fault	DC current sensor fault
E14	GFCI failure	GFCI Device is damaged

## **5. COMMUNICATIONS**

### **5.1 Data communication with RS232**



Fig. 10 RS232 serial port and special RS232 cable

Open the cover of RS232 serial port. Connect the special RS232 cable between the RS232 port on the inverter and the PC. The distance should preferably be less than 10m.

**NOTE:** Please use only the special RS232 cable. If the length is not insufficient, extend it using the “extended RS232 cable” from the local market.

## 5.2 Data communication with RS485 (optional)

### 5.2.1 RS485 Serial Port

The RS485 is used for the purpose of communication between several inverters. Ethernet cable is connected to each inverter. Only three lines of communications are applied: two for signals and one for ground connection.



Fig. 11 The waterproof RJ45 socket and connectors for RS485 port

To help installation, the inverter features two RJ45 sockets to separate input ethernet cable from output ethernet cable.

### 5.2.2 RJ45 Connectors

The RS485 serial connection, whether as a single unit or several inverters as daisy chain, can be performed by means of the RJ45 connectors (See Fig.11).

It makes no difference if its sockets is no.1 or no.2 since they are connected in parallel, and signals are thus the same. One socket is for input ethernet cable with RJ45 connector, another socket is for output ethernet cable with RJ45 connector. The output ethernet cable reaches the following unit.

RS485 pin definition is as follows:

RJ45 connectors			
Pin #	Signal Name	Description	
1		Not Used	
2		Not Used	
3	<b>RTN</b>	<b>Signal Return</b> Common reference for logical signals.	
4		Not Used	
5		Not Used	
6		Not Used	
7	<b>-TR</b>	<b>- Data Line</b> Required for RS485 communication.	
8	<b>+TR</b>	<b>+ Data Line</b> Required for RS485 communication.	

**NOTE:** You can buy T-568B standard Straight-Through ethernet cable to connect two adjacent inverters in local market.

### 5.2.3 RS485 Daisy Chain

RJ45 connectors may be used to connect a single IGSI “SJ” series inverter or multiple IGSI “SJ” series inverters daisy chained together. Up to 31 inverters can be daisy chained. Recommended maximum daisy chain length is 1000m.

With multiple daisy-chained inverters, each unit will be automatically be assigned to a RS485 address within the monitoring software.

The RJ45 socket with 120Ω terminal resistor should be installed at the last inverter in the chain. A special RJ45 socket with terminal resistor and a vacant RJ45 socket in the attached accessories is provided. If the inverter is not the last one in the chain, please remove the terminal resistor and use it as a vacant RJ45 socket.

In order to ensure that the communication on the RS485 line is safe, it is recommended to connect an isolating RS232-485 adapter between the first inverter in the daisy chain system and the PC. Non-isolating RS232-485 adapter can also be used.

The following diagram shows how to connect multiple inverters in a daisy chain configuration.

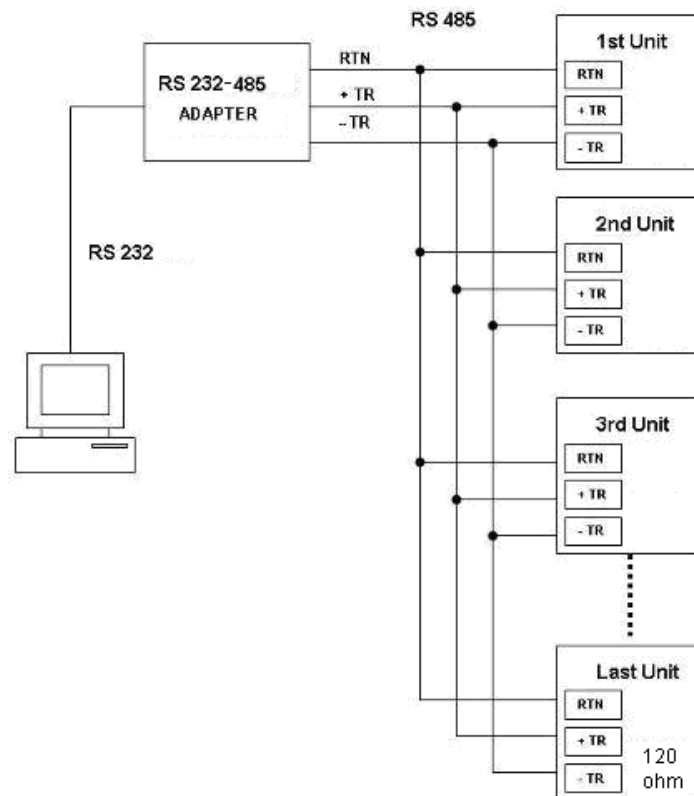

Fig.12 Multiple daisy-chain connection

**NOTE:** The RS485 link supports up to 31 inverters.

**NOTE:** The RJ45 socket with 120Ω terminal resistor should be installed at the last inverter in the chain. Even if there is only one inverter, the 120Ω terminal resistor is also required.

### 5.3 Monitor Inverter

After the RS232 or RS485 link is connected correctly, initiate the monitoring software that is installed from the attached CD. The user can monitor the parameters of the inverters. Detailed information of the inverter is displayed on the right side of the main interface. As to the more detailed setting methods and other functions, please refer to the communicator user's manual in the CD.

## 6. MAINTENANCE

The inverter is maintenance-free.

## 7. TROUBLESHOOTING

In most circumstances, the inverter requires very little servicing. However, if the inverter is not able to operate in accordance to its function, please refer to the following troubleshooting instructions before calling your local dealer or service personnel.

If any problems arise, the "Alarm" LED on the front panel will be red and the LCD displays the relevant information. Please refer to the following table for a list of potential problems and their solution.

DISPLAY		WHAT YOU MAY DO
No any display in LCD or LED		Check PV-input connections
W01	No grid	Check grid connection cables.
W02	Vin overvoltage	Check the Voc of PV string, see if it is greater than or too close to max. input DC voltage of relative inverter type.
E01	Isolation error	Check the impedance is between PV (+) & PV (-) and the PV-Inverter is earthed. The impedance must be greater than 2MΩ.
E02	Leak error	The leakage current is too high. Unplug the inputs from the PV string and check the peripheral AC system.
E03	Grid fault	Make sure grid voltage and frequency meet the specifications

**NOTE:** During periods of little or no sunlight, the solar inverter may continuously start up and shut down. This is due to insufficient power generated to operate the control circuits.

**If you are not able to solve the issues with above troubleshooting procedures, please contact your local dealer or service personnel.**

Before contacting the authorized local dealer or service personnel, please find and keep at hand the following information:

**Information of IGSI “SJ” series inverter**

1. Inverter Model
2. Serial Number
3. Week of manufacture
4. Which LED is red?
5. Which warning/error is displayed?
6. Do you notice whether warning/error can be repeated?

**Information of the PV array**

1. The model and manufacturer of the PV panels
2. Number of strings in the PV array and number of panels per string

## 8. SPECIFICATIONS

Model	IGSI-1500SJ	IGSI-2000SJ	IGSI-3000SJ
<b>DC-Input Parameters</b>			
Max. Input Power (W)	1750	2300	3660
Max. Input Voltage (Vdc)	450	500	
MPPT Operating Range (Vdc)	100 to 450		
Max. Input Current (A)	9	10	20
Numbers of Input	1		2
MPPT Channel	1		
<b>AC-Output Parameters</b>			
Max. Output Power (W)	1650	2200	3400
Rated Output Power (W)	1500	2000	3000
Output Voltage Range (Vac)*	190 to 265	190 to 265	190 to 265
Max. Output Current (A)	7.9	10.5	15.7
Rated Output Voltage (Vdc)	230	230	230
Rated Output Current (A)	6.5	8.7	13
Output Frequency Range (Hz)*	50 ± 5		
Power Factor	> 0.99		
Current Harmonic Distortion (THDi)	< 3%		
Max. Efficiency	> 96%	> 96%	> 96.5%
European Efficiency	> 95%	> 95%	> 95.4%
<b>Environment Parameters</b>			
Protective Level	IP65		
Working Temperature Range (°C)	-25 to +60		
Humidity	0 to 95%, non-condensing		
Ventilation	Natural cooling		
Consumption During Night Time (W)	0		
Noise( dB) - typical	<= 25		
<b>Communication</b>			
LCD	4 lines character display, controls are manipulated through the buttons		
Communication Interface	RS232 (RS485 is optional)		
<b>Mechanical Parameters</b>			
Dimensions (WxDxH) mm	345 x 162 x 354		345 x 162 x 384
Weight (kg)	12	15	17
<b>Others</b>			
Certifications	VDE0126-1-1, DK5940, AS4777, IEC 62109-1, IEC62109-2, EN50178, EN61000, G83/1, CE certification.		

Model	IGSI-5000SJ	IGSI-6000SJ
<b>DC-Input Parameters</b>		
Max. Input Power (W)	5300	6400
Max. Input Voltage (Vdc)	550	
MPPT Operating Range (Vdc)	100 to 500	
Max. Input Current (A) - total	25	27
Numbers of Input	3	
MPPT Channel	1	
<b>AC-Output Parameters</b>		
Max. Output Power (W)	5000	6000
Rated Output Power (W)	4600	6000
Output Voltage Range (Vac)*	190 to 265	
Max. Output Current (A)	23.8	26
Rated Output Voltage (Vac)	230	
Rated Output Current (A)	20	28.6
Output Frequency Range (Hz)*	50 ± 5	
Power Factor	> 0.99	
Current Harmonic Distortion (THDi)	< 3%	
Max. Efficiency	> 97%	> 97%
European Efficiency	> 96%	> 96%
<b>Environment Parameters</b>		
Protective Level	IP65	
Working Temperature Range (°C)	-25 to +60	
Humidity	0 to 95%, no condensation	
Ventilation	Natural cooling	
Consumption During Night Time (W)	0	
Noise (dB)	< 25	
<b>Communication</b>		
LCD	4 lines character display, controls are manipulated through the buttons	
Communication Interface	RS232 & RS485	
<b>Mechanical Parameters</b>		
Dimensions (WxDxH) mm	345 × 162 × 573	
Weight (Kg)	26	27
<b>Others</b>		
Certifications	VDE0126-1-1, DK5940, AS4777, IEC 62109-1, IEC62109-2, EN50178, EN61000, G83/1, CE certification.	